

API Standard Flange Ball Valve

Product Description

Name	Description
Model	Q41F-150LB
Name	API Standard Flange Ball Valve
Size	DN15-DN250
Pressure	150LB
Temp.	-20~150°C
Suitable Medium	Water, steam, oil etc.
Body	WCB/304/316
Seat Sealing	PTFE/PPL/SS/Alloy Metal
Ball	SS201/304/316
Gland	WCB/304/316
Stem	2Cr13/304/316
Lever	DI/304/316

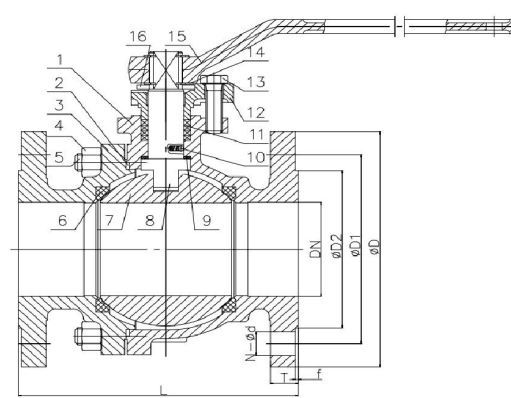

Executive Standard

Name	Standard
Design and Manufacture	API 608
Face to face Length	ASME B16.10
End Flange	ASME B16.5
Pressure Test	API 598

Dimensions

DN	NPS(Inch)	L	D	D1	D2	f	T	N-d
15	1/2"	108	90	60.3	35	2	9.6	4-16
20	3/4"	117	100	69.9	43	2	11.2	4-16
25	1"	127	110	79.4	51	2	12.7	4-16
32	1 1/4"	140	115	88.9	64	2	14.3	4-16
40	1 1/2"	165	125	98.4	73	2	15.9	4-16
50	2"	178	150	120.7	92	2	17.5	4-19
65	2 1/2"	190	180	139.7	105	2	20.7	4-19
80	3"	203	190	152.4	127	2	22.3	4-19
100	4"	229	230	190.5	157	2	22.3	8-19
125	5"	356	255	215.9	186	2	22.3	8-22
150	6"	394	280	241.3	216	2	23.9	8-22
200	8"	457	345	298.5	270	2	27	8-22
250	10"	533	406	362	324	2	28.7	12-25