

Rubber Disc Check Valve

Product Description

| Name | Description |
|------------------------|-------------------------|
| Model | H44X |
| Name | Rubber Disc Check Valve |
| Size | DN50-DN400 |
| Pressure | PN16/150LB |
| Temp. | -10~120°C |
| Suitable Medium | Water, oil, etc. |
| Body | DI |
| Seat | NBR/EPDM |
| Ball | DI+EPDM/NBR |

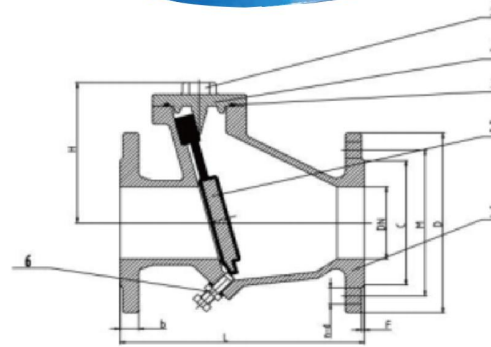

Executive Standard

| Name | Standard |
|-------------------------------|------------------------------------|
| Design and Manufacture | BS EN1074-3, BS EN12334, AWWA C508 |
| Face to face Length | EN558/BSS163, ASME B16.10 |
| Pressure Test | EN12266-1, AWWA C508, API598 |
| Side Flange | EN1092-1, ASME B16.5 |

Dimensions

| DN | NPS(Inch) | L | | | H | D | | C | M | | b | f | n-d | |
|-----|-----------|--------|--------|-----------|-----|--------|------|-----|--------|-------|------|---|--------|-------|
| | | DIN F6 | BS5153 | AWWA C515 | | DIN/BS | AWWA | | DIN/BS | AWWA | | | DIN/BS | AWWA |
| 50 | 2" | 200 | 203 | 203 | 120 | 165 | 152 | 99 | 125 | 120.5 | 19 | 3 | 4-19 | 4-19 |
| 65 | 2 1/2" | 240 | 216 | 216 | 140 | 185 | 178 | 118 | 145 | 139.5 | 19 | 3 | 4-19 | 4-19 |
| 80 | 3" | 260 | 241 | 241 | 168 | 200 | 191 | 132 | 160 | 152.5 | 19 | 3 | 8-19 | 4-19 |
| 100 | 4" | 300 | 292 | 292 | 185 | 220 | 229 | 156 | 180 | 190.5 | 19 | 3 | 8-19 | 8-19 |
| 125 | 5" | 350 | 330 | / | 225 | 250 | 255 | 184 | 210 | 215.9 | 19 | 3 | 8-19 | 8-22 |
| 150 | 6" | 400 | 356 | 356 | 269 | 285 | 279 | 211 | 240 | 241.5 | 19 | 3 | 8-23 | 8-22 |
| 200 | 8" | 500 | 495 | 495 | 312 | 340 | 343 | 266 | 295 | 298.5 | 20 | 3 | 12-23 | 8-22 |
| 250 | 10" | 600 | 622 | 622 | 328 | 405 | 406 | 319 | 355 | 362 | 22 | 3 | 12-28 | 12-25 |
| 300 | 12" | 700 | 698 | 698 | 377 | 460 | 483 | 370 | 410 | 432 | 24.5 | 4 | 12-28 | 12-25 |
| 350 | 14" | 800 | 787 | 787 | 459 | 520 | 533 | 429 | 470 | 476 | 26.5 | 4 | 16-28 | 12-29 |
| 400 | 16" | 900 | 914 | 914 | 437 | 580 | 597 | 480 | 525 | 539.5 | 28 | 4 | 16-31 | 16-29 |