

## Full PTFE Lined Lug Butterfly Valve

### Product Description

Name	Description
Model	LTD371F4-10/16/150LB
Name	Full PTFE Lined Lug Butterfly Valve
Size	DN50-DN1200
Pressure	PN10/16/150LB
Temp.	-20~150°C
Suitable Medium	Water, weak acid and alkali, air, steam, oil, etc.
Body	WCB/CF3/CF3M/CF8/CF8M
Seat	F46/F4/PFA
Disc	WCB/CF3/CF3M/CF8/CF8M lined F46/F4/PFA
Stem	2Cr13/304/316
Actuator	Handle/Worm Gear/Electric/Pneumatic

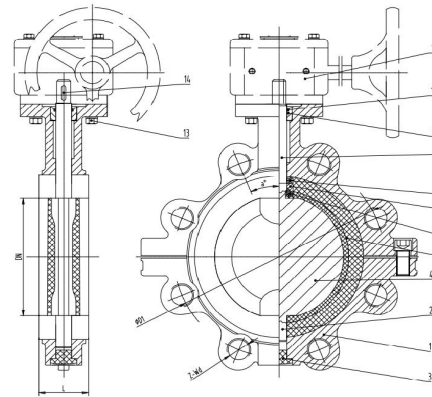

### Executive Standard

Name	Standard
Design and Manufacture	GB/T 12238-2008
Face to face Length	GB/T 12221-2008
End Flange	GB/T 9113-2010, EN1092-1, ASME B16.5
Pressure Test	GB/T 13927-2008

### Dimensions

DN	NPS(Inch)	L	PN10		PN16		Class150	
			ØD1	Z-Ød	ØD1	Z-Ød	ØD1	Z-Ød
50	2"	43	125	4-18	125	4-18	120.6	4-19
65	2 1/2"	46	145	4-18	145	4-18	139.7	4-19
80	3"	46	160	8-18	160	8-18	152.4	4-19
100	4"	52	180	8-18	180	8-18	190.5	8-19
125	5"	56	210	8-18	210	8-18	215.9	8-22.4
150	6"	56	240	8-22	240	8-22	241.3	8-22.4
200	8"	60	295	8-22	295	12-22	298.5	8-22.4
250	10"	68	350	12-22	355	12-26	361.9	12-25.4
300	12"	78	400	12-22	410	12-26	431.8	12-25.4
350	14"	78	460	16-22	470	16-26	476.3	12-28.4
400	16"	102	515	16-26	525	16-30	539.7	16-29
450	18"	114	565	20-26	585	20-30	577.8	16-32
500	20"	127	620	20-26	650	20-30	635	20-32
600	24"	154	725	20-30	770	20-36	749.3	20-35
700	28"	165	840	24-30	840	24-36	863.6	28-35
800	32"	190	950	24-33	950	24-39	977.9	28-41
900	36"	203	1050	28-33	1050	28-39	1085.8	32-41
1000	40"	216	1160	28-33	1170	28-39	1200.2	36-41
1200	48"	276	1380	32-36	1390	32-45	1422.4	44-41