

DI Dual Plate Check Valve

Product Description

Name	Description
Model	DH77X-16Q
Name	DI Dual Plate Check Valve
Size	DN50-DN600
Pressure	PN16
Temp.	-10~120°C
Suitable Medium	Water, oil, etc.
Body	DI/WCB/CF3/CF3M/CF8/CF8M
Seat	NBR/EPDM/PTFE/SI
Disc	DI/WCB/CF3/CF3M/CF8/CF8M
Stem	SS416/2Cr13/304/316
Spring	CF3/CF3M/CF8/CF8M/X750

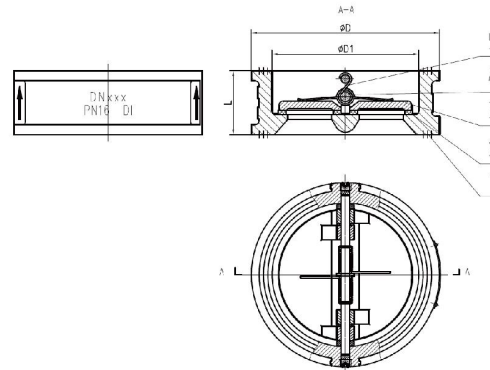

Executive Standard

Name	Standard
Design and Manufacture	JB/T 8937-2010
Face to face Length	JB/T 8937-2010
Pressure Test	GB/T 13927-2008

Dimensions

DN	NPS(Inch)	L	D	D1
50	2"	107	65	43
65	2 1/2"	127	80	46
80	3"	142	94	64
100	4"	162	117	64
125	5"	192	145	70
150	6"	218	170	76
200	8"	273	224	89
250	10"	328	265	114
300	12"	378	310	114
350	14"	438	360	127
400	16"	489	410	140
450	18"	555	450	152
500	20"	594	505	152
600	24"	690	624	178