

Stainless Steel 3PC Ball Valve

Product Description

Name	Description
Model	Q11F-1000WOG
Name	Stainless Steel 3PC Ball Valve
Size	DN15-DN100
Pressure	1000WOG
Temp.	-20~150°C
Suitable Medium	Wafer, steam, oil, nitric acid, acetic acid etc.
Body	CF8/CF8M/CF3/CF3M
Ball	CF8/CF8M/CF3/CF3M
Gland	CF8/CF8M/CF3/CF3M
Seat Sealing Ring	PTFE
Stem	201/CF8/CF8M/CF3/CF3M
Lever	201/CF8/CF8M/CF3/CF3M

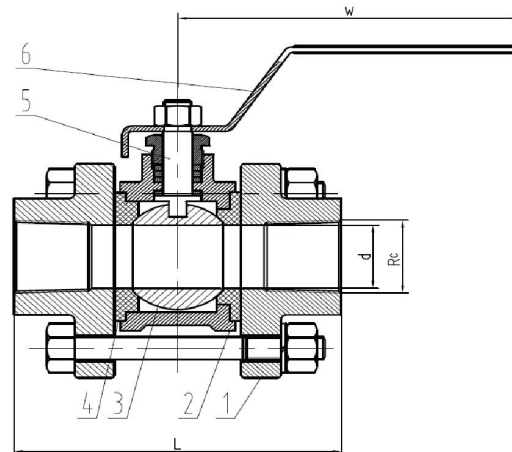

Executive Standard

Name	Standard
Design and Manufacture	GB/T 12237-2007
Face to face Length	GB/T 12221-2005
Pressure Test	GB/T 13927-2008

Dimensions

DN	NPS(Inch)	G	Φd	L	W
15	1/2"	1/2	15	63	90
20	3/4"	3/4	20	73	110
25	1"	1	25	84	120
32	1 1/4"	1 1/4	32	98	130
40	1 1/2"	1 1/2	38	106	150
50	2"	2	50	121	170
65	2 1/2"	2 1/2	64	146	220
80	3"	3	78	166	240
100	4"	4	100	204	320