

Worm Gear Lug Butterfly Valve

► Product Description

Name	Description
Model	LTD371X-10/16/150LB/10K
Name	Worm gear lug Butterfly Valve
Size	DN400-DN1200
Pressure	PN10/16/150LB/10K
Temp.	-20~120°C
Suitable Medium	Fresh water, sewage, seawater, weak acid and alkali, air, steam, etc.
Body	DI/WCB/CF3/CF3M/CF8/CF8M
Seat Seal	NBR/EPDM/PTFE/SI
Disc	DI/CF3/CF3M/CF8/CF8M/C954
Shaft	SS420/2Cr13/304/316
Actuator	Handle/Worm Gear/Electric/Pneumatic

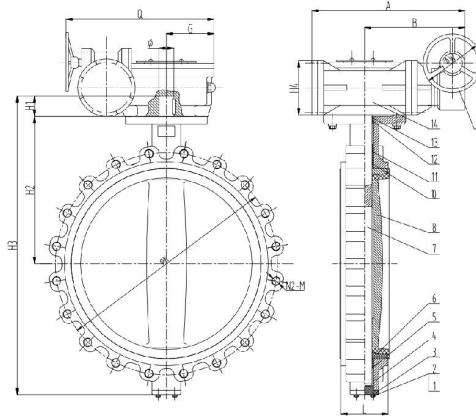

► Executive Standard

Name	Standard
Design and Manufacture	GB/T 12238
Face to face Length	GB/T 12221
End Flange	GB/T 17241.6, EN1092-1, ASME B16.5, JIS 10K
Pressure Test	GB/T 13927

► Dimensions

DN	NPS(Inch)	H1	H2	H3	L	PN10		PN16		150LB		10K	
						ØK	n-Ød	ØK	n-Ød	ØK	n-Ød	ØK	n-Ød
400	16"	52	355	761	102	515	16-26	525	16-30	539.7	16-29	510	16-27
450	18"	52	380	800	114	565	20-26	585	20-30	577.8	16-32	565	20-27
500	20"	64	415	900	127	620	20-26	650	20-30	635	20-32	620	20-27
600	24"	70	475	1090	154	725	20-30	770	20-36	749.3	20-35	730	24-33
700	28"	85	580	1241	165	840	24-30	840	24-36	863.6	28-35	840	24-33
800	32"	85	630	1345	190	950	24-33	950	24-39	977.9	28-41	950	28-33
900	36"	130	680	1502	203	1050	28-33	1050	28-39	1085.8	32-41	1050	28-33
1000	40"	130	800	1651	216	1160	28-33	1170	28-39	1200.2	36-41	1160	28-39
1200	48"	150	941	1955	276	1380	32-36	1390	32-45	1422.4	44-41	1380	32-39

以上信息仅供参考，品工阀门保留更新最新设计的权利，恕不另行通知。下订单前，请与您的销售代表联系。Above information is for reference only. Pango reserves the right to update our latest design without notice. Please check with your sales representative before placing an order.