

Worm Gear Concentric Wafer Butterfly Valve

Product Description

Name	Description
Model	D371X-10/16Q
Name	Worm Gear Wafer butterfly Valve
Size	DN50-DN350
Pressure	PN10/16/150LB/10K
Temp.	-20~120°C
Suitable Medium	Fresh water, sewage, seawater, weak acid and alkali, air, steam, etc.
Body	CI/DI/WCB/CF3/CF3M/CF8/CF8M
Seat Seal	NBR/EPDM/PTFE/SI
Disc	DI/CF3/CF3M/CF8/CF8M/C954
Stem	420/2Cr13/Cr13/304/316
Actuator	Handle/Worm Gear/Electric/Pneumatic

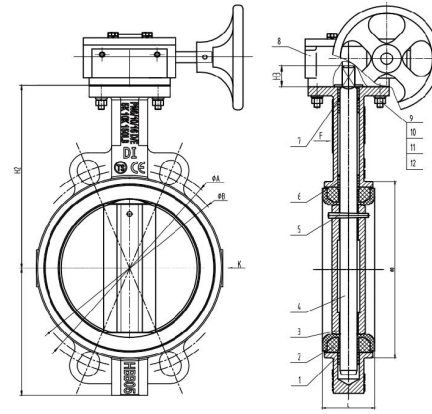

Executive Standard

Name	Standard
Design and Manufacture	GB/T 12238-2008
Face to face Length	GB/T 12221-2008
End Flange	PN10/PN16/10K/150LB
Pressure Test	GB/T 13927-2008

Dimensions

DN	NPS(Inch)	H1	H2	H3	ØA	ØB	L	PN10		PN16		150LB		10K	
								ØK	n-Ød	ØK	n-Ød	ØK	n-Ød	ØK	n-Ød
50	2"	80	129	24	125	105	43	125	4-18	125	4-18	120.6	4-19	120	4-19
65	2 1/2"	82	136	24	145	127	46	145	4-18	145	4-18	139.7	4-19	140	4-19
80	3"	95	153	24	160	145	46	160	8-18	160	8-18	152.4	4-19	150	8-19
100	4"	110	167	24	190.5	165	52	180	8-18	180	8-18	190.5	8-19	175	8-19
125	5"	122	193	27	216	200	56	210	8-18	210	8-18	215.9	8-22.4	210	8-23
150	6"	141	209	27	241.3	225	56	240	8-22	240	8-22	241.3	8-22.4	240	8-23
200	8"	170	251	30	298.4	280	60	295	8-22	295	12-22	298.5	8-22.4	290	12-23
250	10"	213	283	30	361.9	350	68	350	12-22	355	12-26	361.9	12-25.4	355	12-25
300	12"	240	315	30	431.8	400	78	400	12-22	410	12-26	431.8	12-25.4	400	16-25
350	14"	267	368	45	476.2	445	78	460	16-22	470	16-26	476.3	12-28.4	445	16-25