

Concentric Flange Butterfly Valve

► Product Description

Name	Description
Model	D341X-10/16Q
Name	Worm Gear Flanged Butterfly Valve
Size	DN50-350
Pressure	PN10/16/150LB/10K
Temp.	-20~120°C
Suitable Medium	Water, neutral liquid.
Body	DI/WCB/CF8/CF8M/C954
Seat Seal	NBR/EPDM/SI/PTFE/VITON/Wear Resistance/Heat ResistanceFood grade EPDM
Disc	DI/CF8/CF8M/C954
Shaft	SS420/2Cr13/304/316
Actuator	Handle/Worm Gear/Electric/Pneumatic

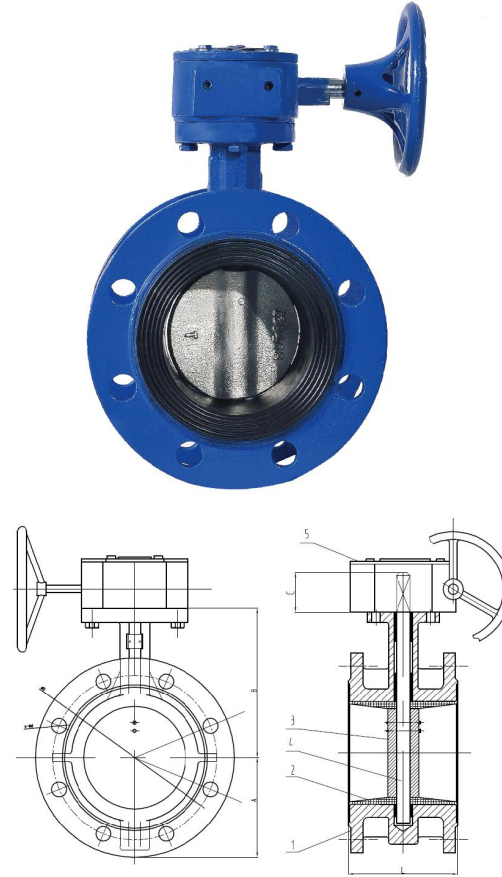

► Executive Standard

Name	Standard
Design and Manufacture	GB/T 12238
Face to face Length	GB/T 12221
End Flange	GB/T 17241.6, EN1092-1, ASME B16.5, JIS10K
Pressure Test	GB/T 13927

► Dimensions

DN	NPS(Inch)	A	B	C	L	ANSI 150LB		PN10		PN16		JIS10K	
						ØK	N-Ød	ØK	N-Ød	ØK	N-Ød	ØK	N-Ød
50	2"	69.5	126.5	32	108	120.7	4-19	125	4-18	125	4-18	120	4-19
65	2 1/2"	72	136	32	112	139.7	4-19	145	4-18	145	4-18	140	4-19
80	3"	88	146	32	114	152.4	4-19	160	8-18	160	8-18	150	8-19
100	4"	96.5	158	32	127	190.5	8-19	180	8-18	180	8-18	175	8-19
125	5"	115	179	32	140	215.9	8-22.4	210	8-18	210	8-18	210	8-23
150	6"	126	197	32	140	241.3	8-22.4	240	8-22	240	8-22	240	8-23
200	8"	161	230	45	152	298.4	8-22.4	295	8-22	295	12-22	290	12-23
250	10"	199	271	45	165	361.9	12-25.4	350	12-22	355	12-26	355	12-25
300	12"	215	305	45	178	431.8	12-22.4	400	12-22	410	12-26	400	16-25
350	14"	261	350	45	190	476.2	12-28.4	460	16-22	470	16-26	445	16-25