

GB/ DIN Standard Ball Check Valve

Product Description

Name	Description
Model	HQ41X-16Q
Name	GB/ DIN Standard Ball Check Valve
Size	DN50-DN300
Pressure	PN16
Temp.	-10~120°C
Suitable Medium	Water, oil, etc.
Body	DI
Seat	NBR/EPDM
Ball	DI+EPDM/NBR

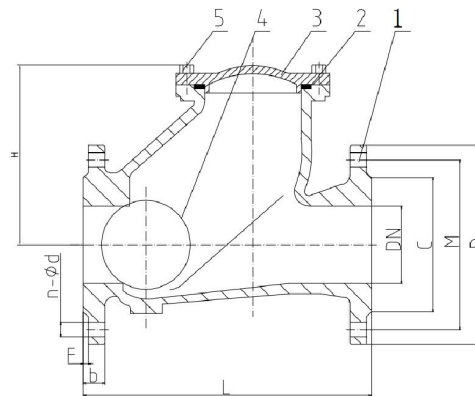

Executive Standard

Name	Standard
Design and Manufacture	MFG
Face to face Length	MFG
Pressure Test	GB/T 13927-2008
Side Flange	GB/T17241.6, EN1092-1

Dimensions

DN	NPS(Inch)	L	H	D	M	b	n-d
50	2"	219	120	160	125	18	4-18
65	2 1/2"	220	130	180	145	18	4-18
80	3"	257	140	195	160	19	8-18
100	4"	280	180	215	180	21	8-18
125	5"	320	190	245	210	22	8-18
150	6"	355	240	280	240	23	8-22
200	8"	435	290	335	290	24	12-22
250	10"	498	300	405	355	27	12-26
300	12"	555	380	460	410	32	12-26