

Stainless Steel Resilient Seat Gate Valve

Product Description

Name	Description
Model	Z45X-10/16, Z41X-10/16
Name	Stainless Steel Resilient Seat Gate Valve
Size	DN50-DN300
Pressure	PN10/16
Temp.	-20~120°C
Suitable Medium	Freshwater, sea water, sewage, weak acid base, air, steam etc.
Body	CF8/CF8M/CF3/CF3M
Wedge	DI+NBR/EPDM
Stem	SS304/316
Actuator	Handwheel/Motorized

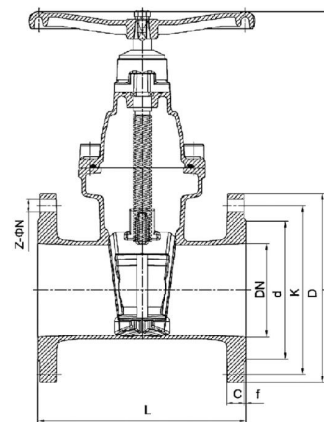

Executive Standard

Name	Standard
Design and Manufacture	GB/T 24924-2010
End Flange	GB/T 17241.6-2008, EN1092-1
Pressure Test	GB/T 13927-2008

Dimensions

Size		D		K		d		Z-ØN		C	L	H
DN	NPS(Inch)	PN10	PN16	PN10	PN16	PN10	PN16	PN10	PN16			
50	2"	160	160	125	125	102	102	4-19	4-19	18	178	225
65	2 1/2"	180	180	145	145	122	122	4-19	4-19	18	190	245
80	3"	195	195	160	160	138	138	8-19	8-19	20	203	280
100	4"	215	215	180	180	158	158	8-19	8-19	20	229	310
125	5"	245	245	210	210	188	188	8-19	8-19	22	254	370
150	6"	280	280	240	240	212	212	8-23	8-23	22	267	415
200	8"	335	335	295	295	268	268	8-23	12-23	24	295	490
250	10"	395	405	350	355	320	320	12-23	12-28	26	330	630
300	12"	445	460	400	410	378	378	12-23	12-28	28	356	705